



*An Online PDH Course
brought to you by
CEDengineering.com*

Engineering Patents II: *Case Study for a Ball Bearing Patent Application*

Course No: LE1-002

Credit: 1 PDH

Robert P. Tata, P.E.



Continuing Education and Development, Inc.

P: (877) 322-5800

info@cedengineering.com

Table of Contents

<u>Subject</u>	<u>Page</u>
Introduction	2
Background	3
Figure 1	4
Figure 2	5
Figure 3	6
Tapered Bearing Gearshaft	8
Figure 4	9
Figure 5	10
Ball Bearing Gearshaft	11
Prior Art	13
Figure 6	14
Figure 7	15
Figure 8	16
Figure 9	17

Introduction

A previously published course "Engineering Patents" examines patents, the patent application process, and a patent granted to a U.S. corporation to improve one of its products. This course examines a patent application that reveals another side of the patent process.

A patent is a document issued by the government that gives the engineering applicant exclusive rights to an invention for a period of 20 years. The invention must be something that is new and useful to society. An invention that is obvious to a person with average skill in a given field is not patentable. Patent laws give individuals and corporations incentive to develop their innovative ideas for their own benefit and for the benefit of others.

There are three types of patents; utility patents, design patents, and plant patents. Engineering patents usually fall into the category of utility patents. Utility patents involve materials, machines and components, as well as manufacturing parts and processes. Design patents involve only the appearance of an article. Plant patents, as the name suggests, are given to those that reproduce a new variety of plants.

Background

There has been a long standing debate among anti-friction bearing engineers as to what type of bearing to use in an application. This course deals with one of the arguments by examining an engineering patent request that suggests the use of angular contact ball bearings to replace tapered roller bearings in a power transmission product.

Angular contact ball bearings are similar to commonly used radial ball bearings except for the alignment of the balls and rings. Radial ball bearings have the balls and rings aligned to support radial loads. Radial loads act perpendicular to the bearing axis of rotation. Angular contact ball bearings have the balls and rings aligned so that the line of contact is at an angle to the perpendicular. They are used to support both radial and thrust loads. Thrust loads act parallel to the bearing axis of rotation. See Figure 1.

Tapered roller bearings have the roller-to-ring contact line act at an angle to the perpendicular similar to angular contact ball bearings. Tapered roller bearings, like angular contact ball bearings, support both radial and thrust loads. See Figure 2.

Angular contact ball bearings operate with virtually pure rolling between the balls and rings. Tapered roller bearings, under load, create forces that act to "squirt" the roller's large end against the inner ring (cone) flange face causing frictional losses that don't exist in angular contact ball bearings. See Figure 3.

Ball bearings have a much lower spring rate (load vs. deflection) than tapered roller bearings. The contact between balls and rings starts out as a point and, as the load increases, evolves into an ellipse. The contact for tapered roller bearings starts out as a line and, under increasing load, changes into a larger rectangular shape. The spring rate of tapered roller bearings is "orders of magnitude" greater than that of ball bearings.

The following pages describe the above mentioned patent application that was submitted for a gearshaft bearing arrangement. Included is a discussion of four existing patents that were selected as "prior art". Prior art are existing patents that are similar to the one being applied for. They can be used by the patent applicant as reasons why his patent should be allowed or they can be used by the Patent Office as reasons why the patent should be denied.

Figure 1

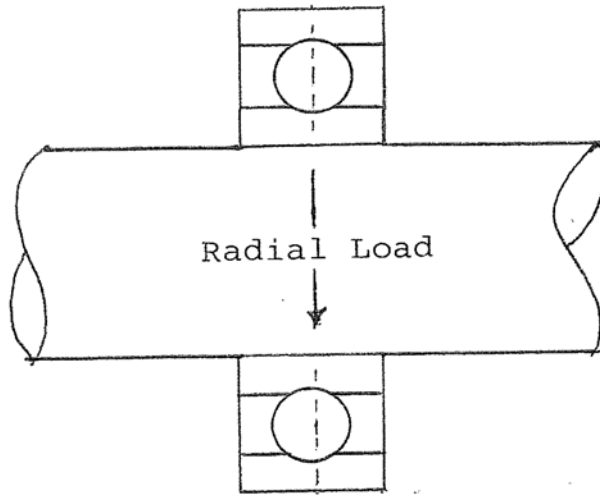

Radial Ball Bearing

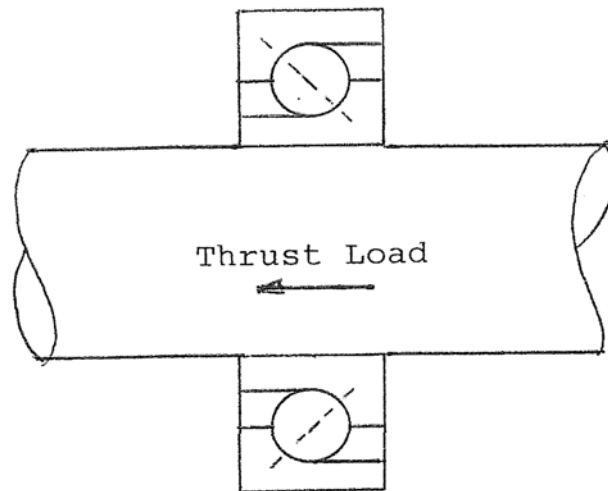

Angular Contact
Ball Bearing

Figure 2

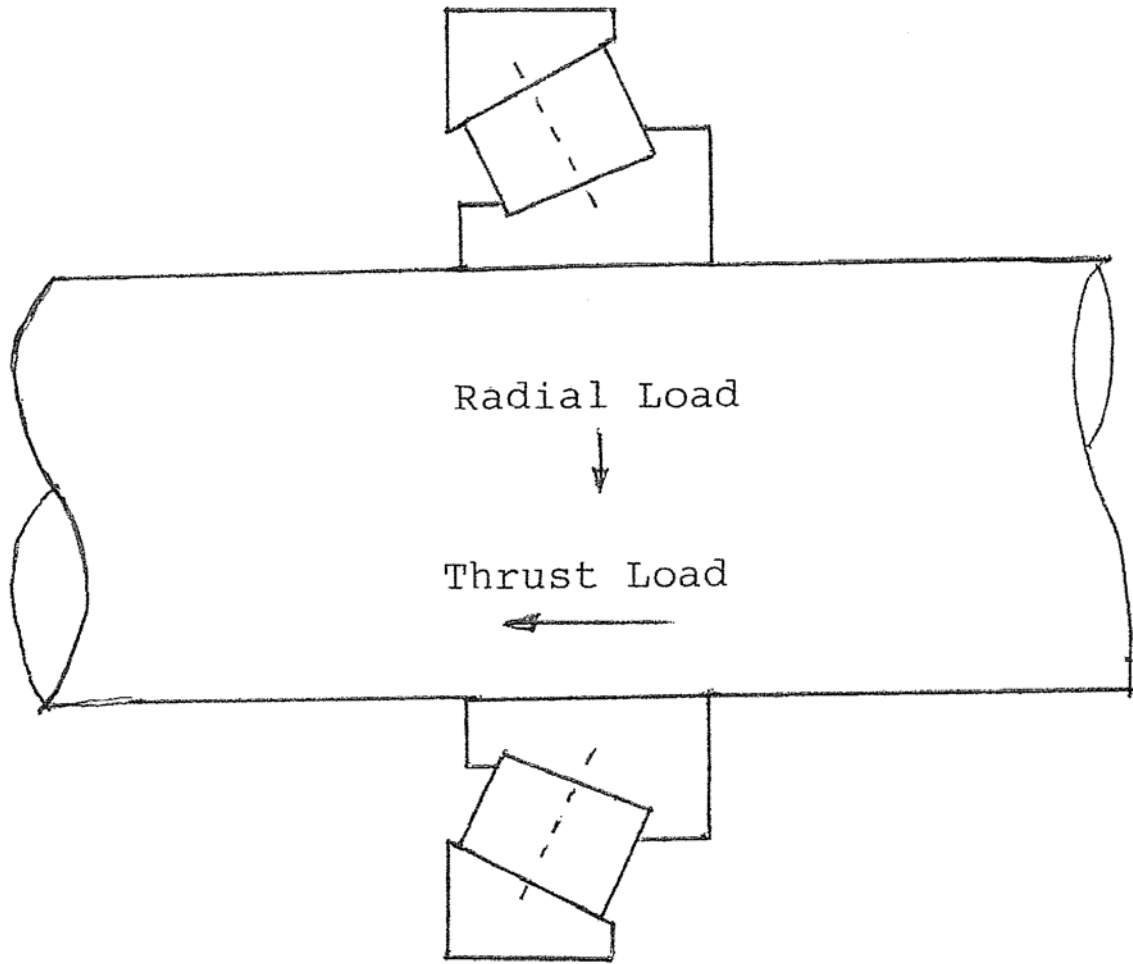

Tapered Roller Bearing

Figure 3

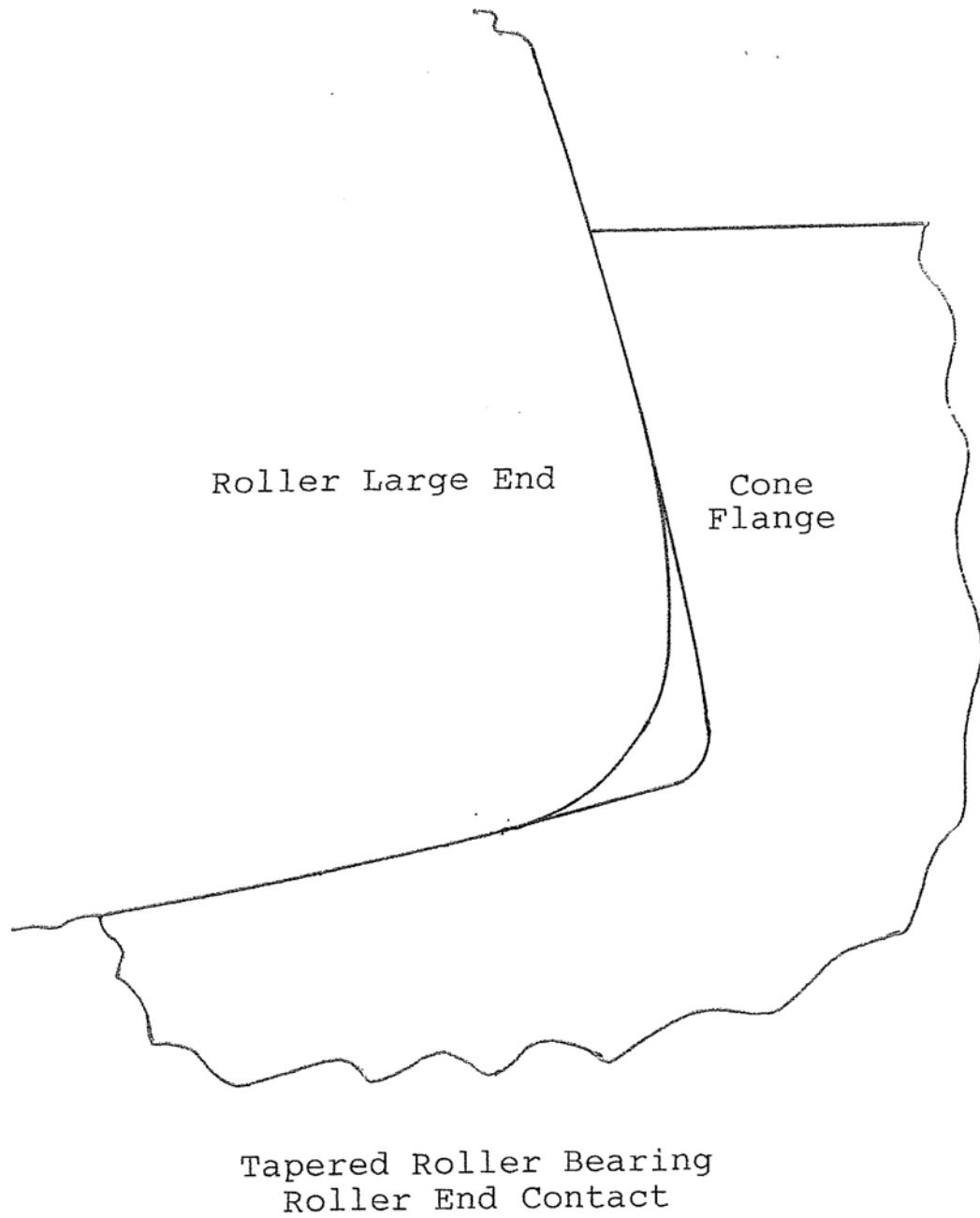

Tapered Roller Bearing Gearshaft

Figure 4 has a cross-sectional view of a conventional gearshaft arrangement. The assembly consists of output gear 1, tapered roller bearings 2, housing 3, gearshaft 4, bearing preload locknut 5, and collapsible spacer 6. The unit is lubricated with gearbox lube which is contained in the assembly by seal 7 and o-ring 8. Flange 9 connects to the driven member. If the output shaft is exposed to the elements, slinger 10 is used to limit foreign element intrusion into the seal area.

Although this type of bearing arrangement has proven successful in some applications, it is not without disadvantages. Gearshaft support bearings have to be preloaded in order to support the shaft with enough rigidity to keep the gears in the proper mesh under all load conditions. To preload gearshaft bearings, an axial load (thrust) is imposed on one bearing that is reacted by the other. In Figure 4, by torquing locknut 5, a thrust load is imposed on the right bearing inner ring (cone). At the same time, the same thrust load is transferred through the housing to the left bearing outer ring (cup) putting the two bearings into compressive preload. As previously discussed, ball bearings have a low spring rate because of the smaller contact pattern between the balls and rings, while tapered roller bearings have a high spring rate because of much larger contact pattern between the rollers and rings. This makes it easy to apply and control preload on ball bearings and very hard to apply and control preload on tapered roller bearings. Too much preload results in potential bearing failure, and too little preload results in potential gear failure. The problem is so acute with tapered roller bearings that they are not normally recommended to be run under preload. Since tapered roller bearings are used in this application and preloading is required, special steps have to be taken for the design to be successful.

During assembly, a unique procedure is used on a special machine in order to set the preload on bearings 2 to the amount needed to support the shaft with enough rigidity to insure proper gear mesh under all power conditions. On this machine, while the gear shaft is rotated, adjusting nut 5 is rotated slightly faster in the same direction until a predetermined torque level is reached. This torque level corresponds to the correct amount of preload that is required for the application. Because tapered bearings are so stiff to the application of load, collapsible spacer 6 must be used to control the rise in torque while the nut is being rotated in order to accurately set the preload.

There is another factor against the use of tapered bearings in this application. Ball bearings operate with virtual pure rolling; however, when tapered roller bearings are under load, the roller's large end is "squirted" or forced against the cone (inner ring) flange face causing sliding friction. This contact produces additional bearing torque and is subject to wear from gear debris and poor lubrication. This, in time, will cause the loss of preload with the resulting adverse affect on the gear mesh. Special precautions in the design and manufacture of the tapered roller's large end and the cone flange face have to be taken for the bearing to operate satisfactorily. Even then, the lubricant must be free of contamination from gear and other hard particle debris. Magnets are put in lubricant sumps in an effort to attract ferrous particles. The lubricant has to be changed after a period of time because of thermal breakdown.

In conclusion, it can be seen that to achieve successful operation of the machinery, extra effort and cost are incurred for gearshafts designed with tapered roller bearings. The following pages will examine a design that a patent was applied for using ball bearings to support the gearshaft. Ball bearings, as explained above, are more easily preloaded and operate with less friction than tapered roller bearings. Included in this case study, will be an analysis of four patents that were investigated as "prior art" (patents that are similar to the one being applied for) that employ the use of ball bearings to support shafts.

Figure 4

Tapered Roller Bearing Gearshaft

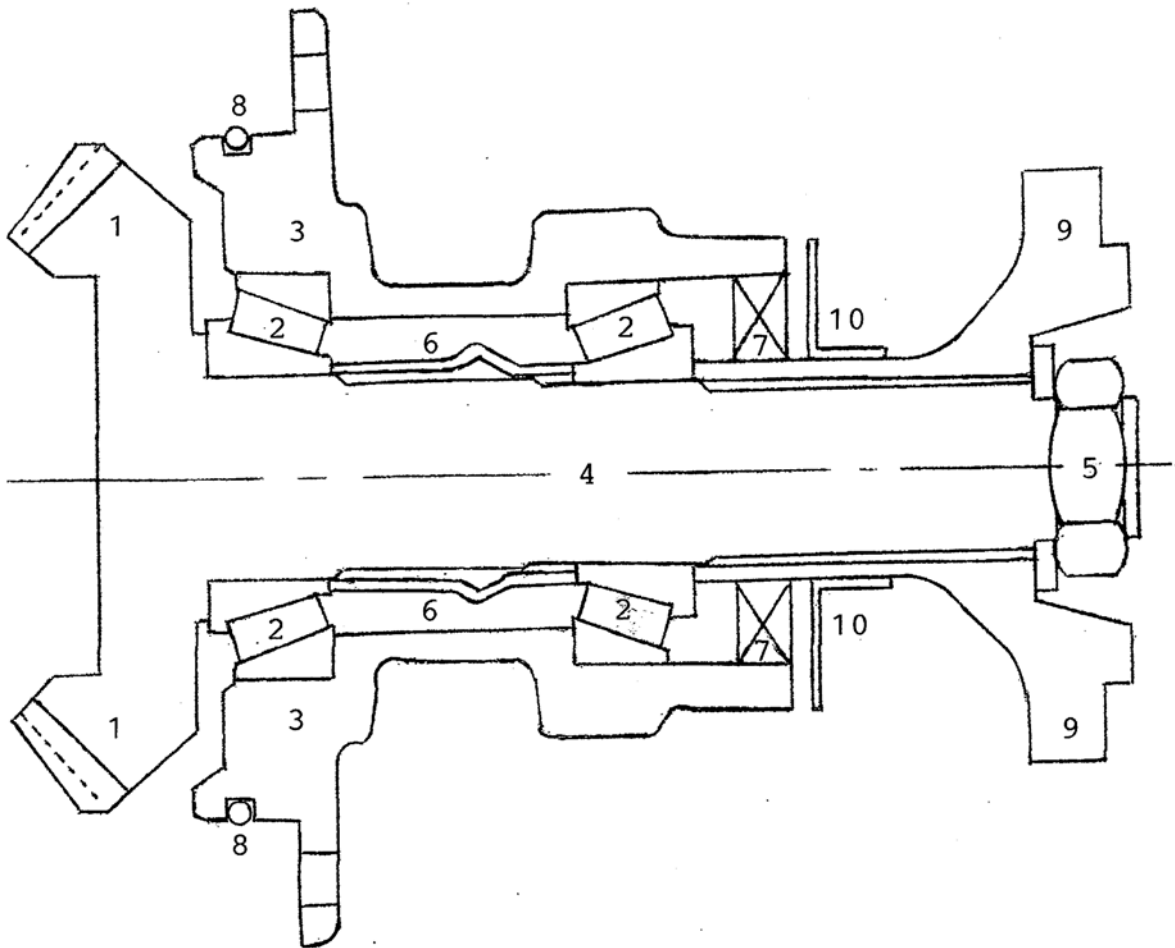

Ball Bearing Gearshaft

Figure 5 has a sketch of a gearshaft similar to Figure 1 except that the tapered roller bearings have been replaced with angular contact ball bearings. Item 1 is the gear. Item 2 are the two angular contact ball bearings. As shown on Figure 2, angular contact ball bearings (as well as tapered roller bearings) have the line of contact between the balls and the two rings of each bearing lie at an angle extending outward from the vertical, which aids in supporting overhanging loads such as the gear in this application. Item 3 is the hub. Item 4 is the gearshaft. Item 5 is the ball bearing clamping nut. Item 6 are the two bearing seals and Item 7 is the slinger seal. Item 8 is an o-ring needed to prevent leakage of the gearbox fluid. Item 9 is the rear drive shaft mounting flange. Item 10 is the mounting flange retaining nut.

The following are explanations of the claims that were given in the patent application describing the advantages of using angular contact ball bearings instead of tapered roller bearings to support gearshafts:

- Ball bearings have a very low spring rate compared to tapered roller bearings; and therefore, preload is more easily set and maintained under all gear load conditions. The preload for the two ball bearings in this design is automatically set by simply tightening locknut 5. This is a much more accurate and easier task than requiring the use of a special machine and a collapsible spacer to set the preload as is required for tapered roller bearings.
- Ball bearings operate with less friction than tapered roller bearings and with less chance of losing preload. Ball bearings rotate with nearly perfect rolling as compared to tapered roller bearings which have sliding friction occurring at the roller/inner ring interface. Also, gear debris and lubricant breakdown cause excessive wear at this interface resulting in loss of preload.
- The angular contact ball bearing design has three of the four ball pathway diameters ground directly in the hub and on gearshaft saving significant machining and assembly time when compared to the tapered roller bearing design where all inner and outer rings are separately manufactured and assembled. One ball bearing inner ring is separable on each bearing so that a full complement of oversized balls can be

assembled into each ball row greatly increasing the capacity of the design and its ability to support heavy gear loads.

- The angular contact ball bearings are designed with a larger diameter and with less separation between the two rows than the tapered roller bearings offering design compactness and more support for the gear because of a stronger housing and shaft.
- The ball bearing design is lubricated with grease and sealed against the entrance of gearbox lubricant which can become contaminated with hard particle debris. Tapered roller bearings do not operate as efficiently with grease lubrication as do ball bearings because of the inability of the lubricant to satisfactorily penetrate the roller/inner ring interface.

Prior Art

Listed below are copies of the first page of four inventions that were investigated as “prior art” in support of the subject patent application:

1) Figure 6, U.S. Patent 4,248,487: This patent shows a compromised version of the means of supporting a gearshaft by using one tapered roller bearing row and one angular contact ball bearing row. This combination of bearings supporting a gearshaft is not commonly used and is shown for informational purposes only.

2) Figure 7, U.S. Patent 3,594,051: Although this patent is concerned with the method of retaining angular contact ball bearings with a special spindle nut 36, it does show that supporting a spindle (shaft) with angular contact ball bearings is not new; however, the spindle supports an overhung wheel, not an overhung gear, which makes this patent unlike the one being requested. The patent being requested may still be allowed based on the difference in applications; however, it does present a weaker argument than if the idea was to be novel to all applications.

3) Figure 8, U.S. Patent 3,792,625: This patent is concerned with the method used in preloading two angular contact ball bearings. The bearings support an overhung gearshaft similar to the one in the subject application, which greatly weakens the main claim of the patent being sought after. The method of setting the preload differs in that a push on the flanged member is used instead of a threaded spindle nut.

4) Figure 9, U.S. Patent 2,174,262: This patent dates back to 1939 and again has angular contact ball bearings 54 and 55 supporting a gearshaft. Ball pathways ground directly on adjoining parts 49 and 50 and bearings are retained with spindle nut 56 similar to the method used in the subject patent application.

The three “prior art” inventions show that supporting gearshafts with angular contact ball bearings, having ground-on pathways and nut preloads, have been in existence for many years and are not patentable. The other claims made for the ball bearing design, such as design compactness and grease lubrication, are considered to be good accompanying features but are not novel; and therefore, are not patentable items. Based on all the above, the subject patent application was denied.

Figure 6

United States Patent [19]
Åsberg

[11] **4,248,487**
 [45] **Feb. 3, 1981**

- [54] **ROLLING BEARING**
 [75] Inventor: **Sture L. Åsberg**, Partille, Sweden
 [73] Assignee: **SKF Nova AB**, Gothenburg, Sweden
 [21] Appl. No.: **15,191**
 [22] Filed: **Feb. 26, 1979**

2,551,503 5/1951 Needham 308/236
 2,692,805 10/1954 Maxwell 308/189 R
 4,150,468 4/1979 Harbottle 308/236

Primary Examiner—Richard R. Stearns
Attorney, Agent, or Firm—Eugene E. Renz, Jr.

[57] **ABSTRACT**

The combination comprising a housing, a shaft journal having a gear wheel at one end, and a bearing assembly rotatably supporting the shaft journal in a cylindrical seat in the housing. The assembly includes a one-piece outer ring having threads on its outer periphery cooperating with threads in the cylindrical seat. The outer ring is rotatable to permit axial adjusting movement of the bearing assembly relative to the housing. The bearing includes two rows of rolling bodies in the annular space between the rings spaced closely relative to one another and an inner race ring on the shaft journal for each of the rows of rolling bodies. One of the rows comprises rollers having axes inclined at an angle to the bearing axis disposed adjacent the gear wheel and the other row of rolling bodies comprises balls which roll against raceways in the ring to provide angular contact disposed at the opposite end of the shaft journal. A locking member engages the threads of the outer ring to permit axial adjustment thereof relative to the housing and abutts the housing to lock the outer ring in a predetermined axial position in the housing.

Related U.S. Application Data

- [63] Continuation of Ser. No. 850,909, Nov. 14, 1977, abandoned.

[30] **Foreign Application Priority Data**

Dec. 1, 1976 [SE] Sweden 7613436
 May 17, 1977 [SE] Sweden 7705758

[51] Int. Cl.³ **F16C 19/49; F16C 23/06**

[52] U.S. Cl. **308/189 R; 308/207 R; 308/236**

[58] **Field of Search** 308/177, 178, 183, 189 R, 308/189 A, 196, 207 R, 207 A, 211, 214, 236

[56] **References Cited**

U.S. PATENT DOCUMENTS

1,099,571 6/1914 Rennerfelt 308/211
 1,476,329 12/1923 Duesenberg 308/189 A
 1,503,849 8/1924 Proctor 308/207 A
 1,511,905 10/1924 Ojdham 308/211
 2,010,965 8/1935 Scrivener 308/189 R
 2,037,982 4/1936 Hughes 308/236
 2,438,542 3/1948 Cushman 308/196

1 Claim, 2 Drawing Figures

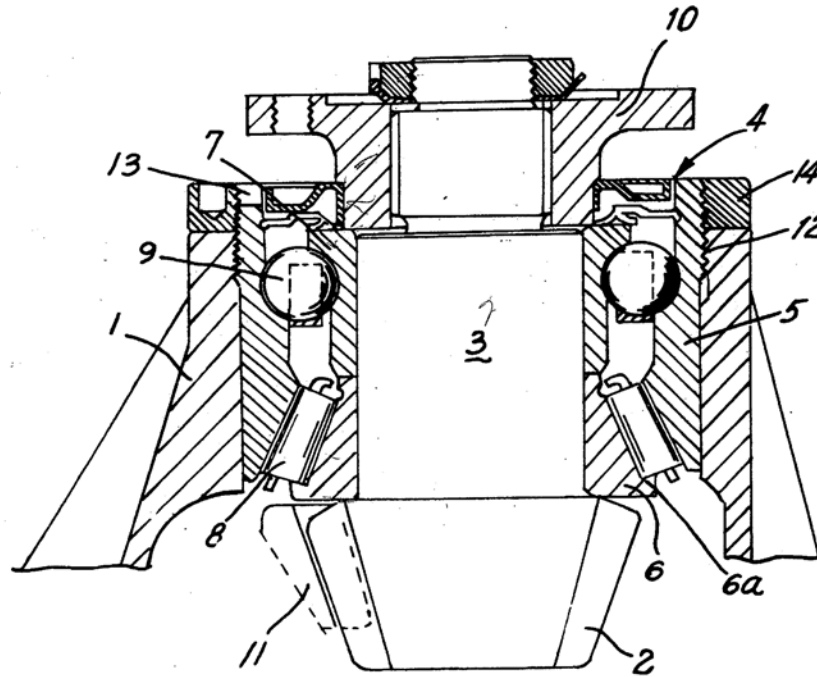

Figure 8

United States Patent [19]
Åsberg

[11] **3,792,625**
 [45] **Feb. 19, 1974**

[54] **PINION GEAR TRANSMISSION**
 [75] **Inventor: Sture Åsberg, Svedalen, Sweden**
 [73] **Assignee: SKF Industrial Trading and Development Co. N.V., Overtoom 141-145, Amsterdam, Netherlands**
 [22] **Filed: June 28, 1971**
 [21] **Appl. No.: 157,594**
 [52] **U.S. Cl. 74/424**
 [51] **Int. Cl. F16h 1/14**
 [58] **Field of Search 74/423, 424, 710, 713; 308/187, 191, 193, 195**

1,835,525 12/1931 Robbins 74/710 X
 1,369,210 2/1921 Zimmerman 74/424 X
 1,708,710 4/1929 Vincent 74/424

Primary Examiner—Benjamin W. Wyche
Assistant Examiner—Frank H. McKenzie, Jr.
Attorney, Agent, or Firm—Howson & Howson; Eugene E. Renz, Jr.

[57] **ABSTRACT**
 Pinion gear transmission comprising a pinion shaft, a pinion wheel at one end of said shaft, connecting means at the opposite end of said shaft for connecting said pinion wheel and shaft to drive means, a housing, bearing means for rotatably supporting said pinion shaft and connecting means relative to said housing, said pinion shaft and connecting means movable axially relative to one another to preload said bearing means and means for permanently fixing said shaft and connecting means with said bearing means preloaded, said shaft, bearing means and connecting means forming an integral unit.

17 Claims, 5 Drawing Figures

[56] **References Cited**

UNITED STATES PATENTS			
1,956,237	4/1934	Hughes	74/424
3,375,727	4/1968	Nasvytis et al.	74/423 X
783,168	2/1905	Baker	74/713
899,891	9/1908	Niclausse	74/713
3,385,133	5/1968	Terao	74/710
3,290,101	12/1966	Recknagel	308/187

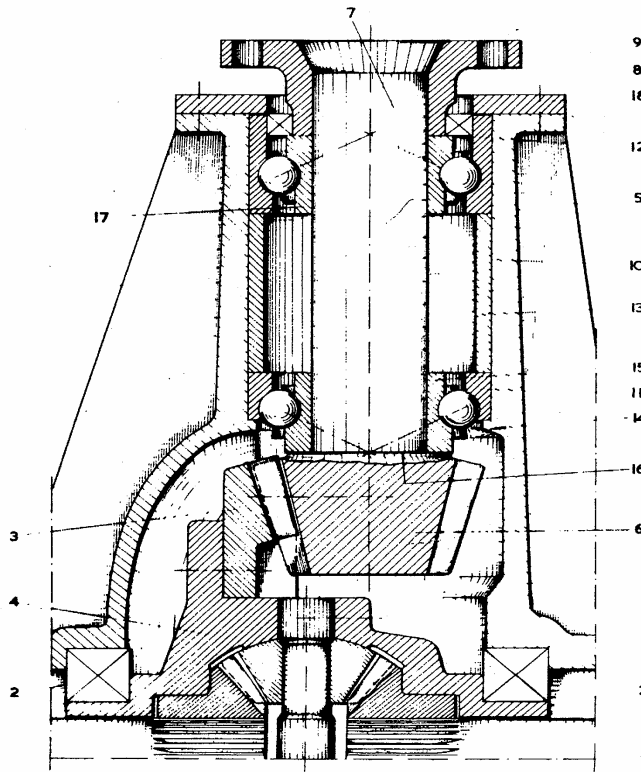

Figure 9

Sept. 26, 1939.

W. R. GRISWOLD

2,174,262

METHOD OF MAKING BEARINGS

Original Filed March 20, 1935

2 Sheets-Sheet 1

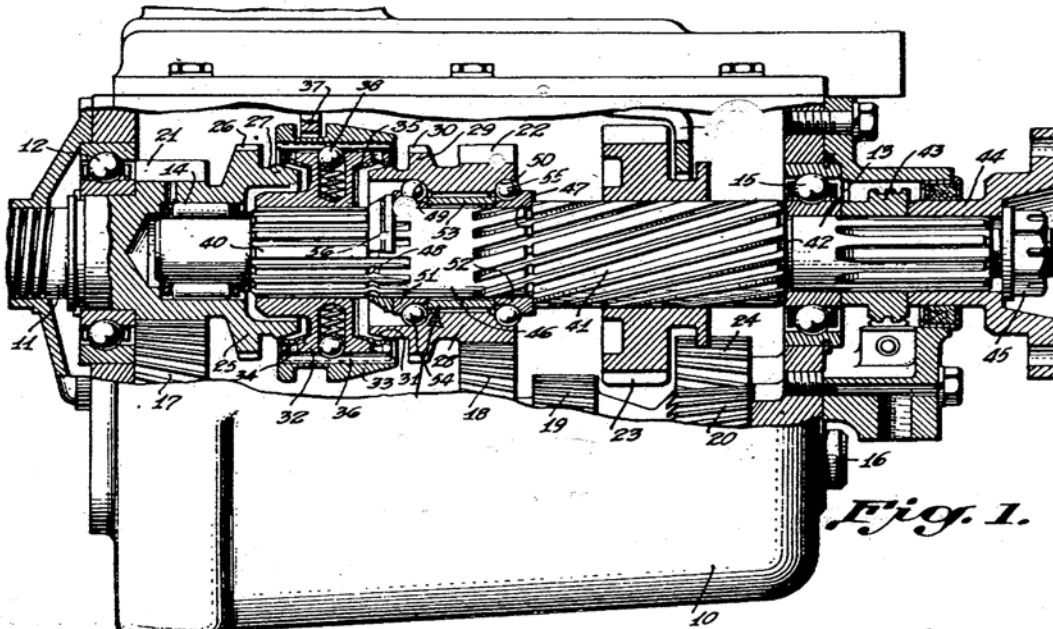

Fig. 1.

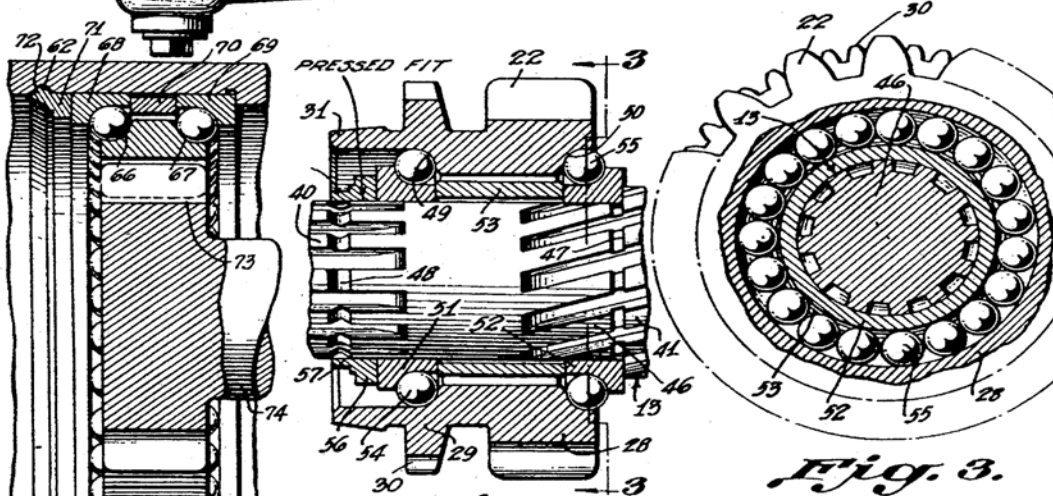

Fig. 2.

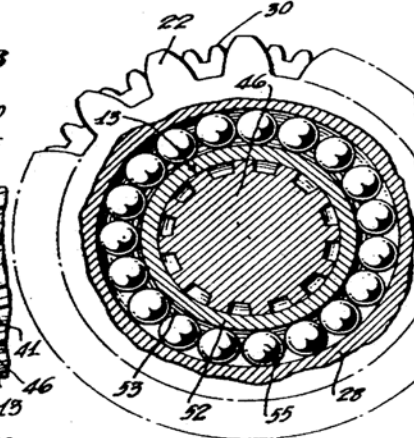

Fig. 3.

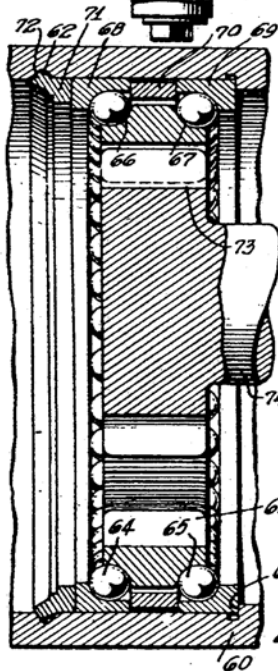

Fig. 4.

Inventor:
Walter R. Griswold

By Sabetts & Hart
Attorneys